

PEG[®] PV substructure

The revolution in utility scale pv power



Reaching the lowest cost of electricity
with a revolutionary new PV plant technology

IT'S NOT EPC,

The PEG System is a revolution in the field of substructures for solar power plants with framed modules.

It is a simple and unique solution and especially designed for east/west orientations. The PEG System delivers the lowest possible levelised cost of electricity (LCOE) with a maximum efficiency of space, constant energy generation over the day and a large volume scalability.

The PEG system significantly reduces both substructure supply and delivery as well as installation costs. Due to the lightweight construction no foundation is needed. The needed material is reduced to less than 50 percent compared to conventional systems.

Less material and a simple design lead to reduced labor costs and the phase between planning and commissioning is reduced significantly. The PEG substructure is the lightest, most efficient and most innovative system on the market. The steel rods of the PEG substructure can also be installed with only a hammer drill. Substructures of our competitors are heavier and more expensive. Most of them need concrete foundations and heavy machines.

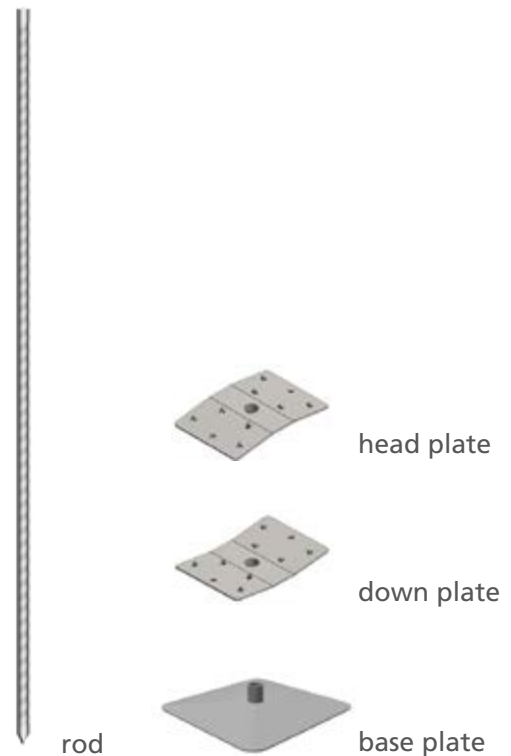

IT'S EPI

Engineering
Procurement
Installation

EFFICIENCY IMPROVEMENT



SIMPLICITY

- Self stabilizing
- Robust & certified for tropical weather
- Low visual impact

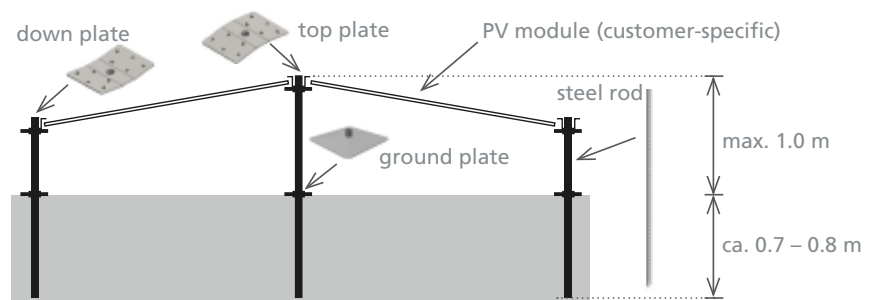

COST REDUCTION



PEG system was formed with a simple goal in mind: create a power unit to deliver electricity at lowest possible levelized costs of energy (LCOE), with best in class technologies, long-term reliability and large volume scalability.

The PEG unit significantly reduces both substructure supply and delivery, as well as installation costs.

* Figures refer to 380W modules and may differ from regionally .

ENGINEERING

most effective land utilization

low visual impact

Fully scalable
from 10kWp to MWs



PROCUREMENT

minimal sourcing
& logistic effort



INSTALLATION

no heavy machines

no cable trenching

no concrete foundations

lower labor skills
required

simpler H&S
procedures on site

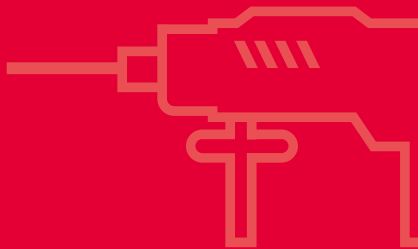

OPERATION

consistent energy
generation across the day

low ecological footprint

robust design

windproof

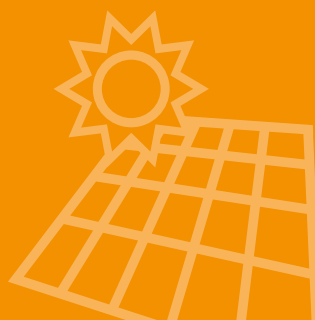

MAINTENANCE

smart solutions
for cleaning & greenkeeping



CONSISTENT GENERATION ACROSS THE DAY

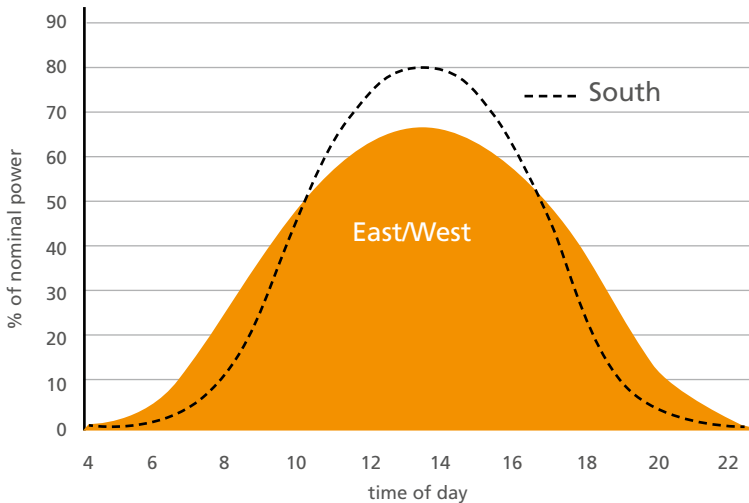

comparison of photovoltaic systems of different orientation on a sunny day (8 July)

APPROVED MODULES

Hanwha Q CELLS
SF, HSL 60, HSL 72, Q.Plus/Peak-G4.X, Q.Plus/Peak BLK-G4.X, Q.Power/Prime-G5X, Q.Power/Prime-L-G5X series

REC
Peak Energy series

Trinasolar
TSM-PC05/PD14

YINGLI SOLAR
YLxxx P-29b and YLXXX C-30b

BVD
60 and 72 cells

CanadianSolar
CSxK-xx, CSxA-xx and CSxV-xx

JA SOLAR
JAM60x/72x-xxx/PR and JAP60x/72x-xxx/SC

Jinko Solar
JKMxxxPP-60 and JKMxxxPP-72 series

SUNTECH
W, V and Vdx series

SOLAR FRONTIER
SFxx-EX-B MP2, SFxxx-L and SFxxx-S MP3

SERAPHIM®
SRP-xxx-6PA/6PB/6MA/6MB xx, MX

risen solar technology
All modules



Australia

10.8MWp PEG system at Queensland, Australia

Further projects are listed at www.jurchen-technology.com/company/references/

Key data

- Super light substructure
- Innovative and simple system
- All components will be installed over-ground
- Specialized aerodynamic proofed design
- No concrete foundations required
- High installation safety

Technical data

Orientation PV array	Patented 8° East-West, fixed tilt, aerodynamic proofed (patent-registered design)
BOM (Bill of material)	1.105 rods and 2.15 clips per module
Large volume scalability	Any power plant capacity from at 10 kWp is possible.
Durability	Hot deep galvanized steel rods and pre-galvanized steel plates. PV modules and clips based on corrosion-free aluminum and glass. All DC cabling components are weatherproof and UV resistant.
Wind loads	Designed for 2,400Pa module pressure load; compliance with wind codes is TBD by local engineering company per wind region
Approved ambient temperature	Up to 50°C (up to 55°C with Hot Climate Option)
Certifications	Clamping approval from module manufacturers. Wind load certificate by local engineering firm in accordance with local wind codes. The PEG substructure is UL certified.

Requirements

Land soil condition	Cohesive (e.g. sandy-clay, clayey silt) and non-cohesive soil (e.g. sand or sand-gravel).
Upper soil layer	No rocks or underground infrastructure up to 1m below ground; rammed depth up to 0.8m
Site slopes	The PEG system can be installed on slopes of up to 4.5 deg. In case the slope is up to 2 deg, the rods should be vertical to the horizontal plane. In case the slope is higher than 2 deg., the rods should be vertical to ground slope.



Jurchen Technology GmbH
Steigweg 24
97318 Kitzingen
Germany

phone: +49 (0) 9321 2680 600
fax: +49 (0) 9321 2680 699
E-Mail: info@jurchen-technology.com
www.jurchen-technology.com



PV substructure
conforms to
UL Std. 2703